

## 8P023700

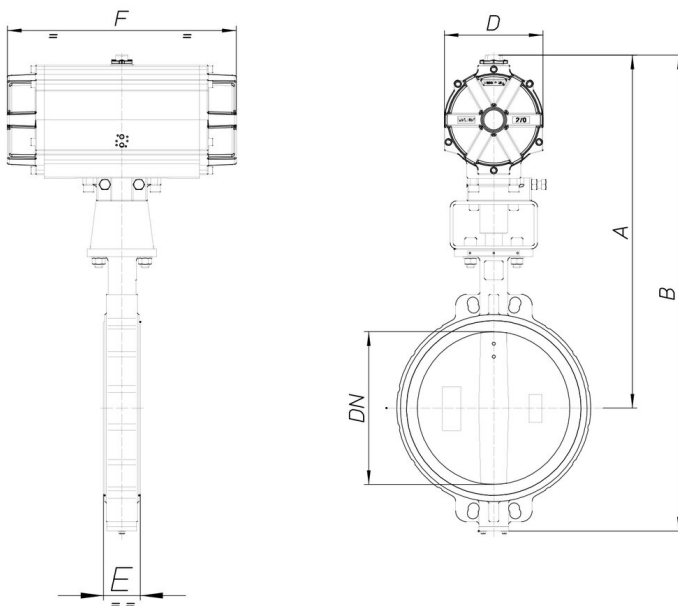

Absperrklappe "WAFER" PN10, Gehäuse aus Grauguss G250, Klappenscheibe aus Sphäroguss GGG40 vernickelt, Dichtung EPDM, mit Antrieb.

### Technische Spezifikationen



MOD	PN	A	B	D	E	F	ACT.	RI
8P02370097	10	709	968	186	80	500	DA 160	4236
8P02370098	10	798	1107	217	107	579	DA 200	4171
-	10	820	1147	217	119	579	DA 200	4171
8P02370099	10	908	1269	217	132	579	DA 200	4237
8P02370060	10	1111	1570	290	156	672	DA 270	4172

