

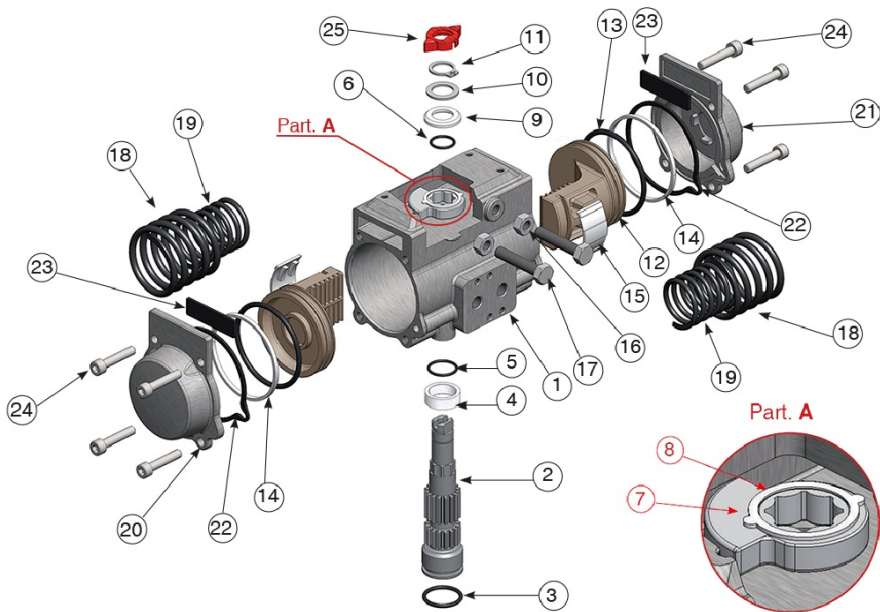

## MOD. 52

### Technical specifications

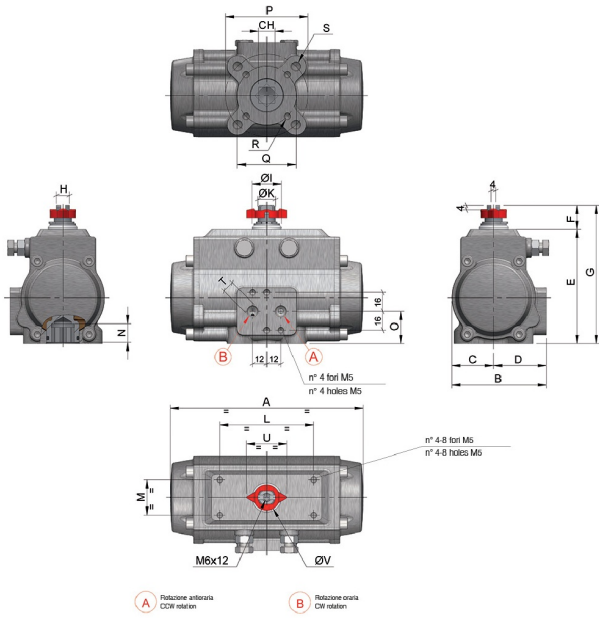



VALIDO DA MOD. 52 A MOD. 100  
 VALID FROM MOD. 52 TO MOD. 100

**SET DI MOLLE  
 SPRING SETS**

STANDARD SET 05

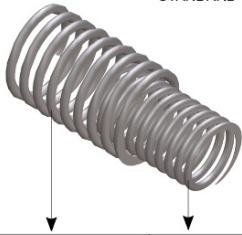

SET	MOLLA ESTERNA EXTERNAL SPRING	MOLLA INTERNA INTERNAL SPRING
01	1	1
02	2	-
03	1	2
04	2	1
05	2	2

POSITION	PART NAME	MATERIAL	TREATMENT	N.º PIECES
1	Body	Stainless steel	Hard anodized	1
2	Anti-blowout pinion	Stainless steel	-	1
• 3	O-ring	NBR/SILICONE/FKM	-	1
• 4	Spacer ring	POM-AMODEL-STANYL	-	1
• 5	O-ring	NBR/SILICONE/FKM	-	1
• 6	O-ring	NBR/SILICONE/FKM	-	1
7	Cam	Stainless steel	-	1
8	Spacer	POM-MINLON	-	1
• 9	Spacer	POM-MINLON	-	1
10	Washer	Stainless steel	-	1
11	Snap ring	Stainless steel	-	1
12	Piston	Die cast aluminium	Hard anodized	2
• 13	O-ring	NBR/SILICONE/FKM	-	2
• 14	Antifriction ring	POM-AMODEL-STANYL-PTFE	-	2
• 15	Thrust block	POM-AMODEL-STANYL	-	2
16	Stop bolt retaining nut	Stainless steel	-	2
17	Stop bolt	Stainless steel	-	2
18	External spring	Acciaio-steel	Powder coating (bonderizing)	See spring setting
19	Internal spring	Acciaio-Steel	Powder coating (bonderizing)	See spring setting
20	Left end cap	Stainless steel	-	1
21	Right end cap	Stainless steel	-	1
22	End cap seats	NBR/SANTOPRENE/SILICONE/FKM/ME0020-70	-	2
23	End cap seats	NBR/SANTOPRENE/SILICONE/FKM/ME0020-70	-	2
24	End cap fixing screw	Stainless steel	-	8
25	Position indicator	Gomma termoplastica TPEThermoplastic rubber TPE	-	1

• Parts subject to wear

MOD	FORATURA DRILLING ISO 5211	CH	A	B	C	D	E	F	G	H	Ø I	Ø K	L	M	N	O	P	Q	R	S	T ISO 7/1	U	Ø V
MOD. 52	F03-F05	11	141	71	30	41	85,5	20	105,5	10	21	12	80	30	12	26,5	50	36	M5X7,5	M6X9	1/8"	34,5	22

## Applications



FOOD & BEVERAGE



HVAC



PULP & PAPER



PAINTS & SOLVENTS



WATER TREATMENT



CHEMICAL



OEM



OIL & GAS