

MOD. 100

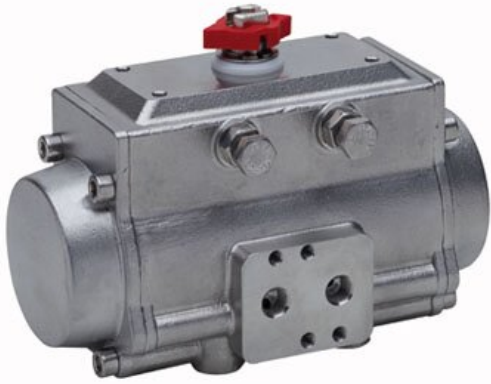

Technical specifications

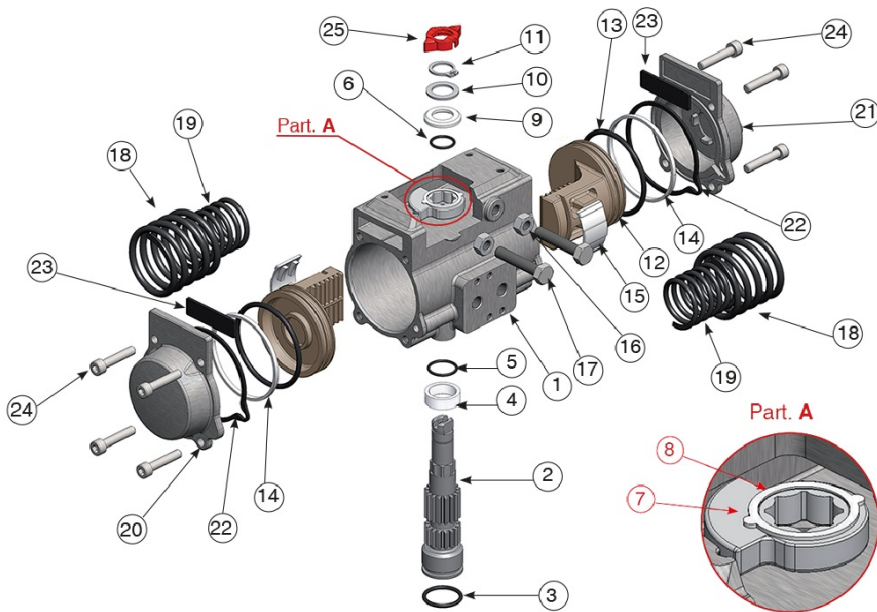

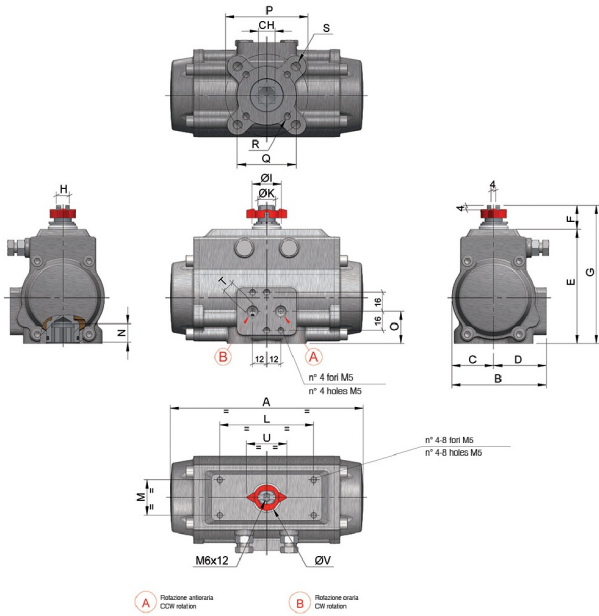

POSITION	PART NAME	MATERIAL	TREATMENT	N.° PIECES
1	Body	Stainless steel	-	1
2	Anti-blowout pinion	Stainless steel	-	1
• 3	O-ring	NBR/SILICONE/FKM	-	1
• 4	Spacer ring	POM-AMODEL-STANYL	-	1
• 5	O-ring	NBR/SILICONE/FKM	-	1
• 6	O-ring	NBR/SILICONE/FKM	-	1
7	Cam	Stainless steel	-	1
8	Spacer	POM-MINLON	-	1
• 9	Spacer	POM-MINLON	-	1
10	Washer	Stainless steel	-	1
11	Snap ring	Stainless steel	-	1
12	Piston	Die cast aluminium	Hard anodized	2
• 13	O-ring	NBR/SILICONE/FKM	-	2
• 14	Antifriction ring	POM-AMODEL-STANYL-PTFE	-	2
• 15	Thrust block	POM-AMODEL-STANYL	-	2
16	Stop bolt retaining nut	Stainless steel	-	2
17	Stop bolt	Stainless steel	-	2
18	External spring	Acciaio-steel	Powder coating (bonderizing)	See spring setting
19	Internal spring	Acciaio-Steel	Powder coating (bonderizing)	See spring setting
20	Left end cap	Stainless steel	-	1
21	Right end cap	Stainless steel	-	1
22	End cap seats	NBR/SANTOPRENE/SILICONE/FKM/ME0020-70	-	2
23	End cap seats	NBR/SANTOPRENE/SILICONE/FKM/ME0020-70	-	2
24	End cap fixing screw	Stainless steel	-	8
25	Position indicator	Gomma termoplastica TPEThermoplastic rubber TPE	-	1

• Parts subject to wear

MOD	FORATURA DRILLING ISO 5211	CH	A	B	C	D	E	F	G	H	Ø I	Ø K	L	M	N	O	P	Q	R	S	T ISO 7/1	U	Ø V
MOD. 100	F07-F10	17	275	123	55	68	143,8	20	163,8	15	35	22	80	30	20,5	52,5	102	70	M8X9	M10X14	1/4"	42	29

Applications



FOOD & BEVERAGE



HVAC



PULP & PAPER



PAINTS & SOLVENTS



WATER TREATMENT



CHEMICAL



OEM



OIL & GAS

