

# MOD. 140

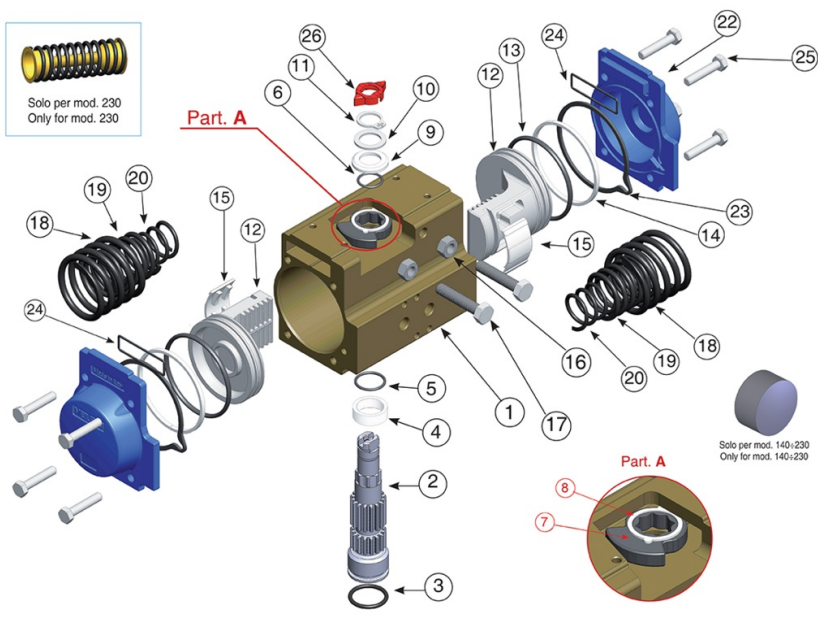

## Spécifications techniques

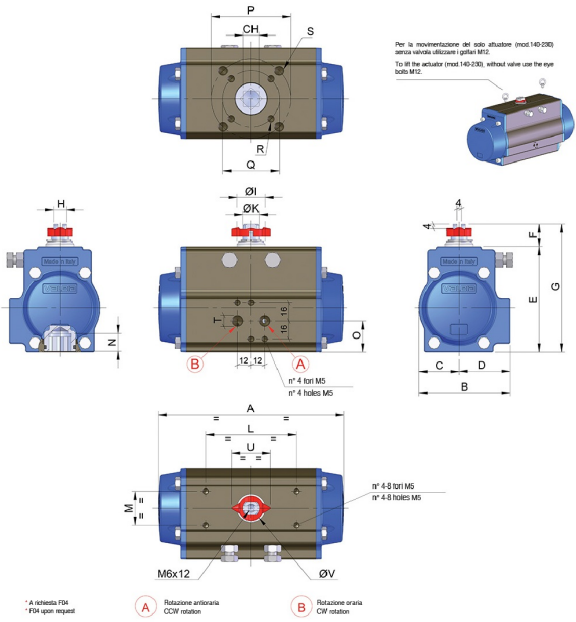



VALIDO DA MOD. 52 A MOD. 140  
 VALID FROM MOD. 52 TO MOD. 140

SET DI MOLLE  
 SPRING SETS

STANDARD SET 05

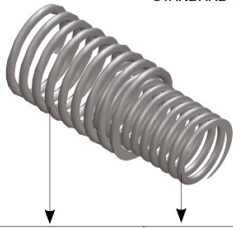

SET	MOLLA ESTERNA EXTERNAL SPRING	MOLLA INTERNA INTERNAL SPRING
01	1	1
02	2	-
03	1	2
04	2	1
05	2	2

POSITION	NOM DE LA PIÈCE	MATÉRIEL	TREATMENT	N.° PIÈCES
1	Body	Extruded aluminium	Hard anodized	1
2	Anti-blowout pinion	Steel	Nichelato - Nickel plated	1
• 3	O-ring	NBR/SILICONE/FKM	-	1
• 4	Spacer ring	POM/AMODEL/STANYL/PEEK	-	1
• 5	O-ring	NBR/SILICONE/FKM	-	1
• 6	O-ring	NBR/SILICONE/FKM	-	1
7	Cam	Stainless steel	-	1
8	Spacer	POM/MINLON/PTFE/PEEK	-	1
• 9	Spacer	POM/MINLON/PTFE/PEEK	-	1
10	Washer	Stainless steel	-	1
**11	Snap ring	Steel	Nickel plated	1
12	Piston	Die cast aluminium	-	2
• 13	O-ring	NBR/SILICONE/FKM	-	2
• 14	Antifriction ring	POM/AMODEL/STANYL/PTFE/MINLON/PEEK	-	2
• 15	Thrust block	POM-AMODEL-STANYL-DELIRIN+MOS2/PEEK	-	2 [4]
16	Stop bolt retaining nut	Stainless steel	-	2
17	Stop bolt	Stainless steel	-	2
18	External spring	Steel	Painted	See spring setting
***19	Central spring	Steel	Painted	See spring setting
20	Internal spring	Steel	Painted	See spring setting
21	Left end cap	Die cast aluminium	Painted	1
22	Right end cap	Die cast aluminium	Painted	1
23	End cap seats	NBR/SANTOPRENE/SILICONE/FKM/ME0020-70	-	2
24	O-ring	NBR/SILICONE/FKM	-	2
25	End cap fixing screw	Stainless steel	-	8
26	Position indicator	Gomma termoplastica TPEThermoplastic rubber TPE	-	1

• Parts subject to wear

\* \* Reinforcedseries DIN 471-UNI 7436 Valid for mod. 140-160-180-200-230 only.

\* \* \* Only for mod. 160-180-200. Only square connection at 45°

MOD	FORATURA DRILLING ISO 5211	CH	A	B	C	D	E	F	G	H	Ø I	ØK	L	M	N	O	P	Q	R	S	T ISO 7/1	U	ØV
MOD. 140	F10 - F12	27	435	164	76,5	87,5	197	30	227	24	49	35	80/130	30	29	71	125	102	M10X15	M12X18	1/4"	64	44

## Applications



FOOD & BEVERAGE



HVAC



PULP & PAPER



PAINTS & SOLVENTS



WATER TREATMENT



CHEMICAL



OEM



OIL & GAS