

# MOD. 330

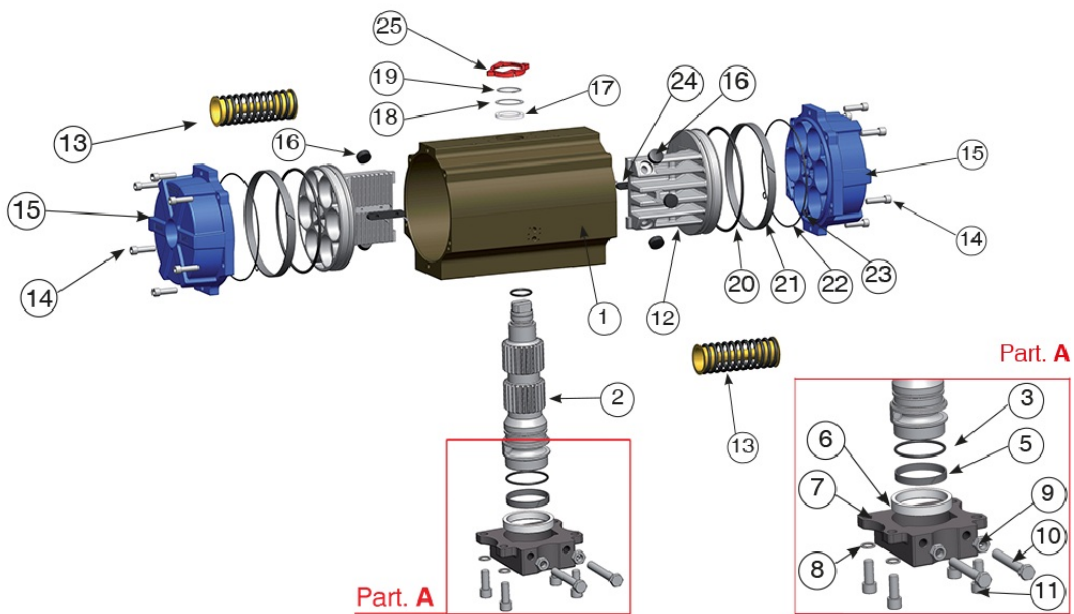

## Spécifications techniques

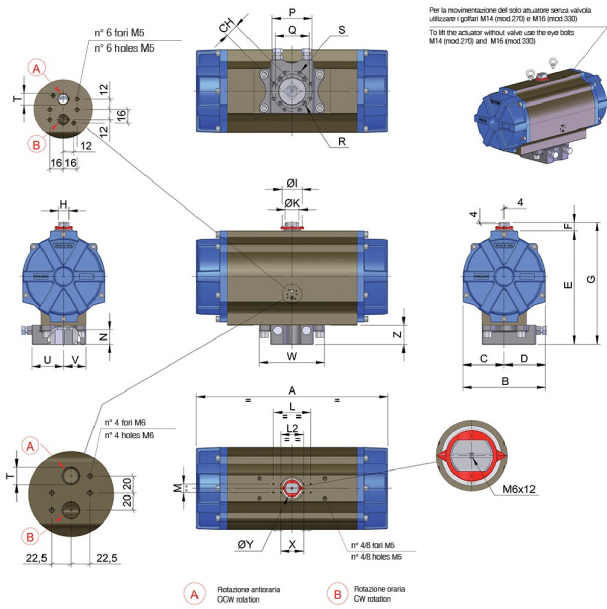



VALIDO DA MOD. 230 A MOD. 330  
VALID FROM MOD. 230 TO MOD. 330

SET DI MOLLE  
SPRING SETS

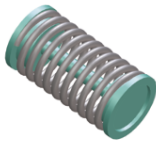

MOLLA UNICA PRECOMPRESSA  
PRETENSIONED SPRING

SET	N° MOLLE PER LATO N° OF SPRINGS FOR EACH SIDE	MOD.230 MOD.270 e 330
01	2/3	
02	3/3	
03	3/4	
04	4/4	
05	4/5	
06	5/5	
07	5/6	
08	6/6	

POSITION	NOM DE LA PIÈCE	MATÉRIEL	TREATMENT	N.° PIÈCES
1	Body	Extruded aluminium	Hard anodized	1
2	Anti-blowout pinion	Steel	Nickel plated	1
• 3	O-ring	NBR/SILICONE/FKM	-	1
• 4	O-ring	NBR/SILICONE/FKM	-	1
• 5	Antifriction ring	P.T.F.E 15% graphite	-	1
• 6	Antifriction ring	P.T.F.E	-	1
7	Plate	mod.330 C45	Painted	1
8	Washer	Stainless steel	-	4
9	Stop bolt retaining nut	Stainless steel	-	2
10	Stop crew	Steel	Zinc plated	2
11	Fixing screws	Stainless steel	-	4
12	Piston	Die cast aluminium	-	2
13	Precompressed spring	Steel	Painted	See spring setting
14	End cap fixing screw	Stainless steel	-	mod. 270 12
14	End cap fixing screw	mod. 330 16	-	mod. 330 16
• 15	End cap	Die cast aluminium	Painted	2
• 16	Thrust block	DELIN+MOS2	-	mod.330 8
16	Thrust block	mod.330 8	-	mod.330 8
17	Spacer ring	POM	-	1
• 18	Pinion washer	Stainless steel	-	1
• 19	Snap ring	Steel	Nickel plated	1
20	O-ring	NBR/SILICONE/FKM	-	2
21	Antifriction ring	P.T.F.E 15% graphite	-	2
22	O-ring	NBR/SILICONE/FKM	-	2
23	O-ring	NBR/SILICONE/FKM	-	mod. 270 4
24	Anti blowout key	POM	-	2
25	Position indicator	Gomma termoplastica TPE Thermoplastic rubber TPE	-	1

### • Parts subject to wear

MOD	FORATURA DRILLING ISO 5211	CH	A	B	C	D	E	F	G	H	Ø I	Ø K	L	L2	M	N	P	Q	R	S	T ISO 7/1	U	V	W	Z	X	Ø Y
MOD. 330	F16-F25	55	881	402	201	201	505	50	555	36	109	50	130	/	30	62	254	165	M20X30	M16X26	1/2"	129	135	297	95	80,5	60

## Applications



FOOD & BEVERAGE



HVAC



PULP & PAPER



PAINTS & SOLVENTS



WATER TREATMENT



CHEMICAL



OEM



OIL & GAS