

MOD. 52

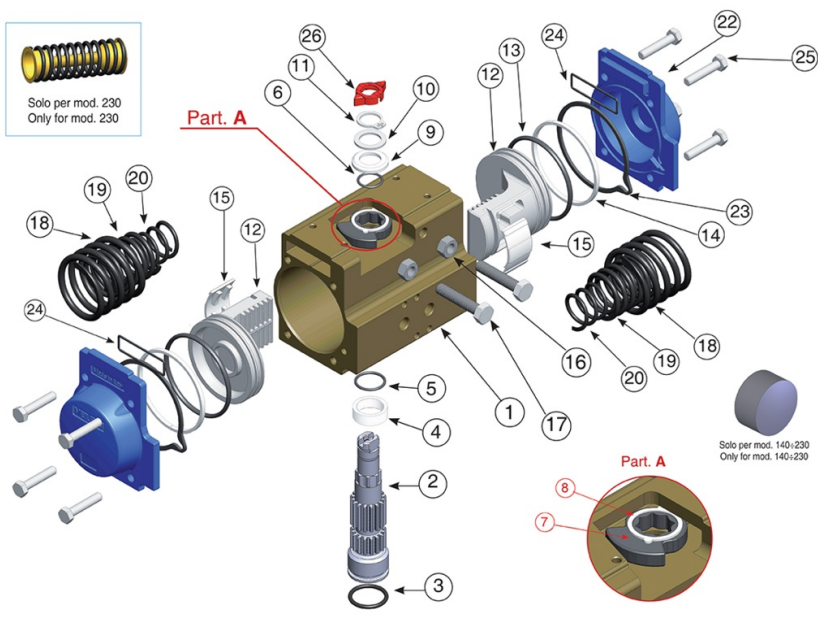

Specifiche tecniche

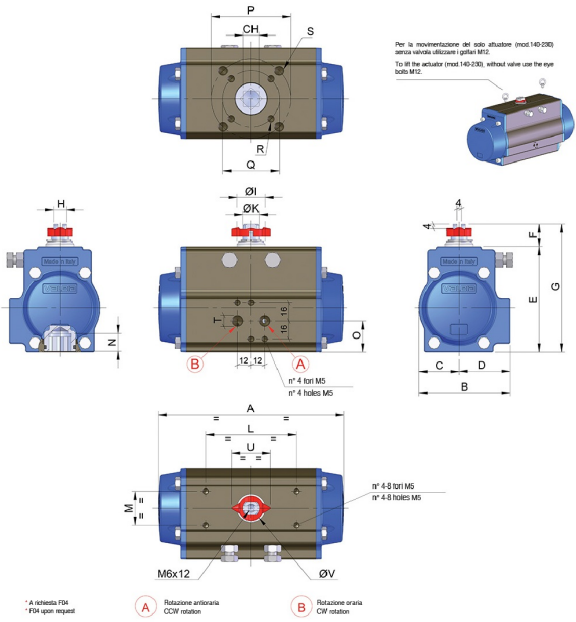



VALIDO DA MOD. 52 A MOD. 140
 VALID FROM MOD. 52 TO MOD. 140

SET DI MOLLE
 SPRING SETS

STANDARD SET 05

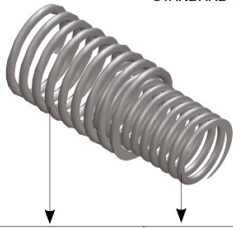

SET	MOLLA ESTERNA EXTERNAL SPRING	MOLLA INTERNA INTERNAL SPRING
01	1	1
02	2	-
03	1	2
04	2	1
05	2	2

POSIZIONE	NOME PARTE	MATERIALE	TRATTAMENTO	N.° PEZZI
1	Corpo	Extruded aluminium	Ossidato duro	1
2	Pignone antiespulsione	Steel	Nichelato	1
• 3	O-ring	NBR/SILICONE/FKM	-	1
• 4	Anello distanziale	POM/AMODEL/STANYL/PEEK	-	1
• 5	O-ring	NBR/SILICONE/FKM	-	1
• 6	O-ring	NBR/SILICONE/FKM	-	1
7	Camma	Stainless steel	-	1
8	Anello camma	POM/MINLON/PTFE/PEEK	-	1
• 9	Anello sotto seeger -Spacer	POM/MINLON/PTFE/PEEK	-	1
10	Rondella	Stainless steel	-	1
**11	Seeger	Steel	Nichelato	1
12	Pistone	Die cast aluminium	-	2
•13	O-ring	NBR/SILICONE/FKM	-	2
•14	Anello antifrizione	POM/AMODEL/STANYL/PTFE/MINLON/PEEK	-	2
•15	Pattino reggispinta	POM-AMODEL-STANYL-DELIRIN+MOS2/PEEK	-	2 [4]
16	Dado di bloccaggio reg.	Stainless steel	-	2
17	Vite di regolazione	Stainless steel	-	2
18	Molla esterna	Steel	Verniciata	Vedi set molle
***19	Molla centrale	Steel	Verniciata	Vedi set molle
20	Molla interna	Steel	Verniciata	Vedi set molle
21	Tappo sinistro	Die cast aluminium	Verniciato	1
22	Tappo destro	Die cast aluminium	Verniciato	1
23	Guarnizioni Tappi	NBR/SANTOPRENE/SILICONE/FKM/ME0020-70	-	2
24	O-ring	NBR/SILICONE/FKM	-	2
25	Vite di serraggio tappi	Stainless steel	-	8
26	Indicatore di posizione	Gomma termoplastica TPEThermoplastic rubber TPE	-	1

• Particolari soggetti ad usura.

** Serie rinforzata DIN 471-UNI 7436 [4] Vale solo per mod. 140-160-180-200-230

*** Solo per mod. 160-180- 200 ** Solo quadro 45°

MOD	FORATURA DRILLING ISO 5211	CH	A	B	C	D	E	F	G	H	Ø I	Ø K	L	M	N	O	P	Q	R	S	T ISO 7/1	U	Ø V
MOD. 52	F03-F05	11	141	71	30	41	81,5	20	101,5	10	21	12	80	30	12	26,5	50	36	M5X7,5	M6X9	1/8"	34,5	22

Applicazioni



FOOD & BEVERAGE



HVAC



PULP & PAPER



PAINTS & SOLVENTS



WATER TREATMENT



CHEMICAL



OEM



OIL & GAS