

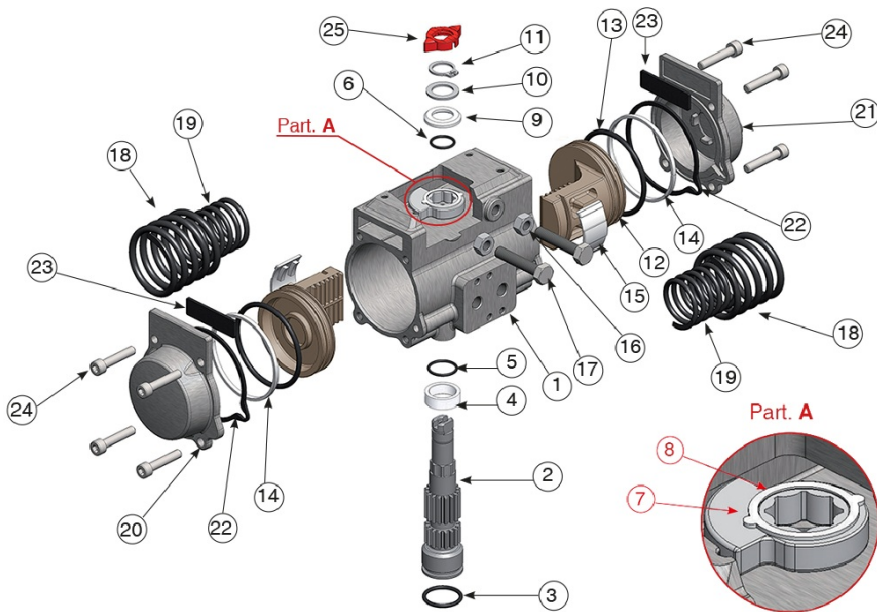

MOD. 52

Specifiche tecniche

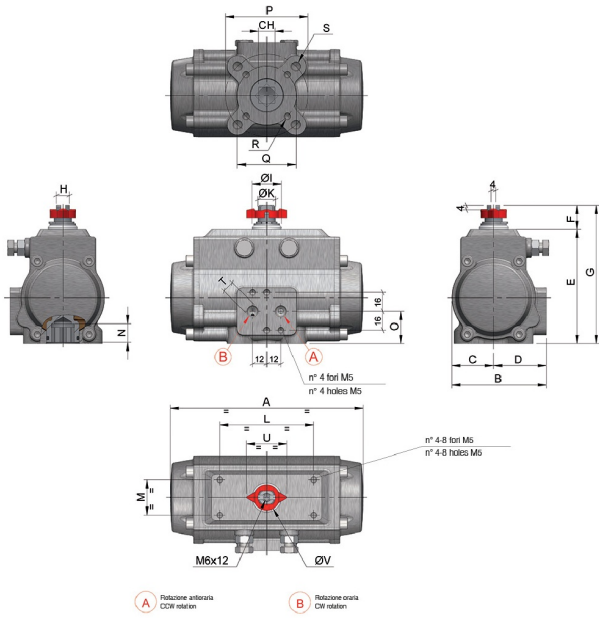



VALIDO DA MOD. 52 A MOD. 100
 VALID FROM MOD. 52 TO MOD. 100

**SET DI MOLLE
 SPRING SETS**

STANDARD SET 05

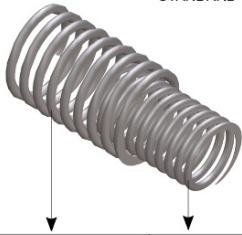

SET	MOLLA ESTERNA EXTERNAL SPRING	MOLLA INTERNA INTERNAL SPRING
01	1	1
02	2	-
03	1	2
04	2	1
05	2	2

POSIZIONE	NOME PARTE	MATERIALE	TRATTAMENTO	N.° PEZZI
1	Corpo	Stainless steel	Ossidato duro	1
2	Pignone antiespulsione	Stainless steel	-	1
• 3	O-ring	NBR/SILICONE/FKM	-	1
• 4	Anello distanziale	POM-AMODEL-STANYL	-	1
• 5	O-ring	NBR/SILICONE/FKM	-	1
• 6	O-ring	NBR/SILICONE/FKM	-	1
7	Camma	Stainless steel	-	1
8	Anello camma	POM-MINLON	-	1
• 9	Anello sotto seeger	POM-MINLON	-	1
10	Rondella	Stainless steel	-	1
11	Seeger	Stainless steel	-	1
12	Pistone	Die cast aluminium	Ossidato duro	2
• 13	O-ring	NBR/SILICONE/FKM	-	2
• 14	Anello antifrizione	POM-AMODEL-STANYL-PTFE	-	2
• 15	Pattino reggispinta	POM-AMODEL-STANYL	-	2
16	Dado di bloccaggio reg.	Stainless steel	-	2
17	Vite di regolazione	Stainless steel	-	2
18	Molla esterna	Acciaio-steel	Verniciata a polvere (bonderizzazione)	Vedi set molle
19	Molla interna	Acciaio-Steel	Verniciata a polvere (bonderizzazione)	Vedi set molle
20	Tappo sinistro	Stainless steel	-	1
21	Tappo destro	Stainless steel	-	1
22	Guarnizioni tappi	NBR/SANTOPRENE/SILICONE/FKM/ME0020-70	-	2
23	Guarnizioni tappi	NBR/SANTOPRENE/SILICONE/FKM/ME0020-70	-	2
24	Vite di serraggio tappi	Stainless steel	-	8
25	Indicatore di posizione	Gomma termoplastica TPEThermoplastic rubber TPE	-	1

• Particolari soggetti ad usura.

MOD	FORATURA DRILLING ISO 5211	CH	A	B	C	D	E	F	G	H	Ø I	Ø K	L	M	N	O	P	Q	R	S	T ISO 7/1	U	Ø V
MOD. 52	F03-F05	11	141	71	30	41	85,5	20	105,5	10	21	12	80	30	12	26,5	50	36	M5X7,5	M6X9	1/8"	34,5	22

Applicazioni



FOOD & BEVERAGE



HVAC



PULP & PAPER



PAINTS & SOLVENTS



WATER TREATMENT



CHEMICAL



OEM



OIL & GAS